

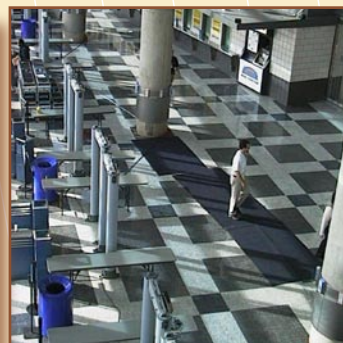

**METAL DETECTORS**

**HI-PE/CF**

**A SECURELY  
OPEN BANK**



# HI-PE/CF



## A SECURELY OPEN BANK

Specifically designed to detect firearms in high-flowrate entrances, the **HI-PE/CF** combines the characteristic reliability of CEIA products with very high discrimination of metal personal effects, even if these are numerous and of significant dimensions.

In banking applications, the technical innovations implemented in the **HI-PE/CF** Firearms Detector now allow the number of people stopped to be reduced to a fifth, compared with the best Metal Detectors available until today, while maintaining the same level of security.

From now on mobile phones, make-up containers, domestic objects, palm-top organizers and other such items can be readmitted into bank branches, creating a virtually-open bank for customers while simultaneously maintaining the block on dangerous weapons.

The **HI-PE/CF** has provided confirmation of these characteristics in numerous bank installations.

The **HI-PE/CF** represents the definitive complete, flexible and highly-integrated answer for a **Securely Open Bank**.



### Traditional airlock bank entrances: the situation today.

The nuisance alarms in current airlock-type entrances fitted with metal detectors are mainly due to mobile phones and female customers' handbags and their contents.

In these systems, if the metal detector is correctly calibrated to detect conventional and light-alloy firearms such as the Beretta Model 950 B, 6.35 calibre, the rate of nuisance alarms varies from 35% to 55%.

A reduction in sensitivity reduces the alarm rate, but is not a solution in that it also reduces security, allowing medium-sized firearms to be brought in.

"Abuse" of the manual reset of the metal detector alarm by the branch staff also results in a reduction in security levels.

# The HI-PE/CF Firearms Detector

CEIA recently introduced a Weapons Detector designed especially for the bank access control sector, with the following functional results:

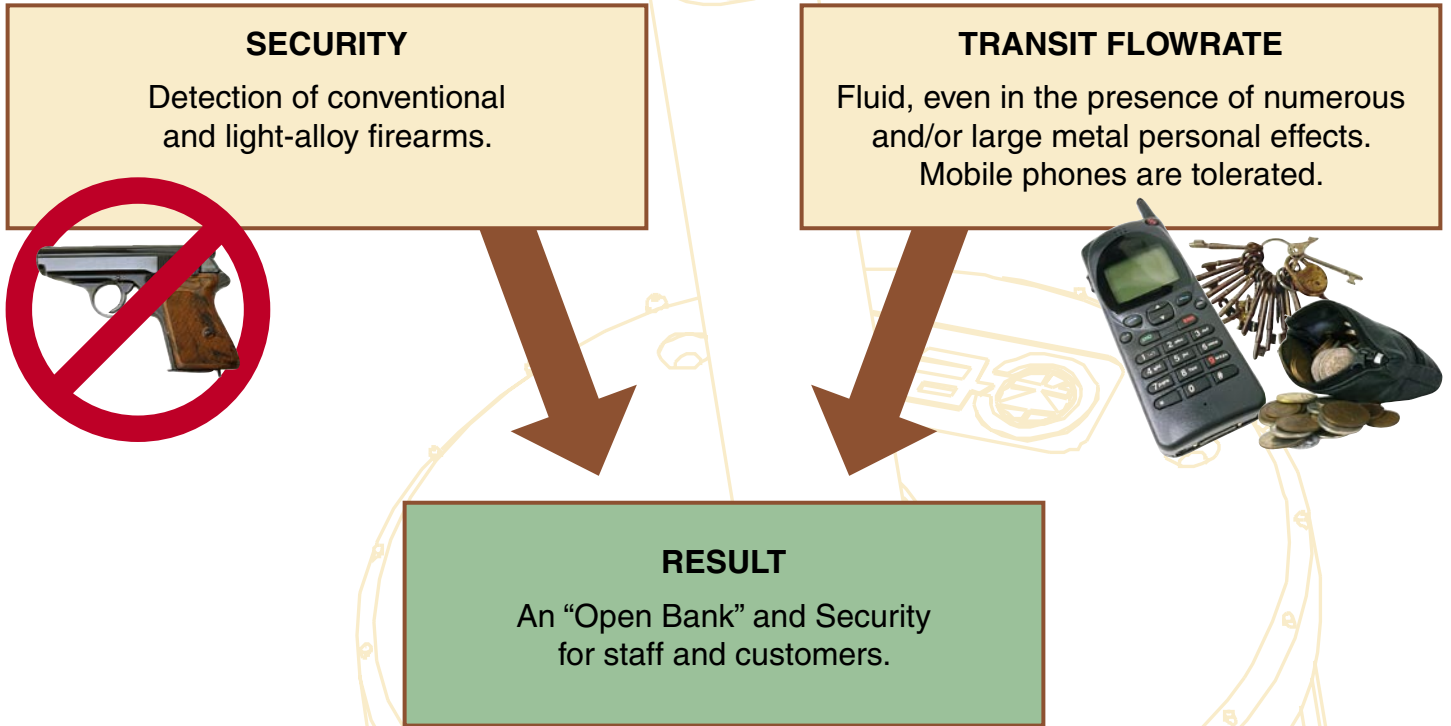

## Main characteristics

This is an innovative, specific device for the detection of firearms, whether magnetic or non-magnetic, with simultaneous discrimination of personal metal effects such as:

- Large quantities of keys or coins
- Mobile phones
- Walkmans and/or Palm-top organizers
- Metal cosmetics containers
- Watches and jewellery



### How it works

The two figures below illustrate the difference in response between a traditional metal detector and the new **HI-PE/CF** Firearms Detector. Note the clear increase in discrimination achieved by the latter:

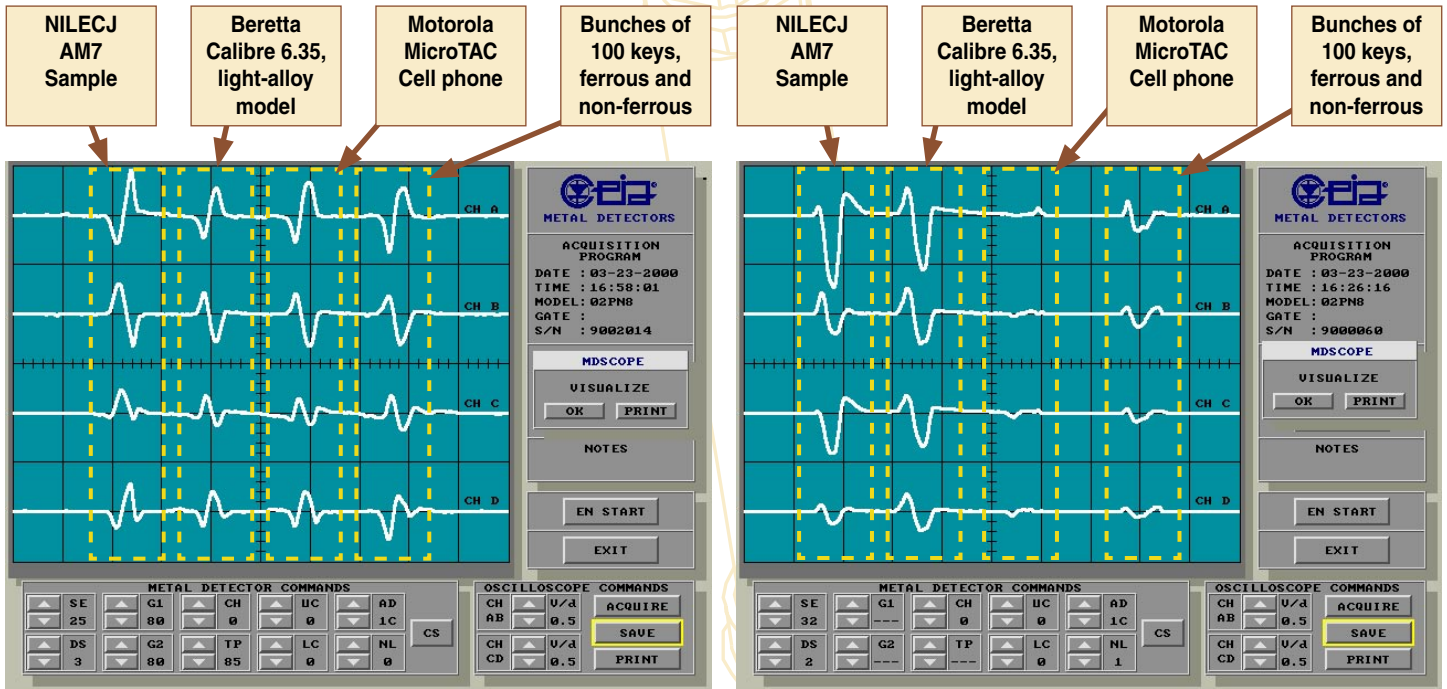

Traditional Metal Detector

HI-PE/CF Firearms Detector

## Airlock Entrances with HI-PE/CF Firearms Detector

### Comparison with entrances with traditional metal detector

The entrance with the **HI-PE/CF** Firearms Detector allows 93 out of 100 people through while guaranteeing detection of conventional and light-alloy firearms (Security Reference: NILECJ AM7 Beretta Model 950 B Calibre 6.35 in light alloy).

The comparison was carried out on two entrances installed at a bank branch, originally equipped with traditional metal detectors and subsequently updated with **HI-PE/CF** Firearms Detectors.

### A certain contribution to Security

The **HI-PE/CF** Firearms Detector incorporates the experience accumulated from more than 25,000 metal detectors installed in banks.

The use of this detector, together with other complementary technology, allows construction of bank access control systems with innovative characteristics in terms of **Flowrate** and **Security**.

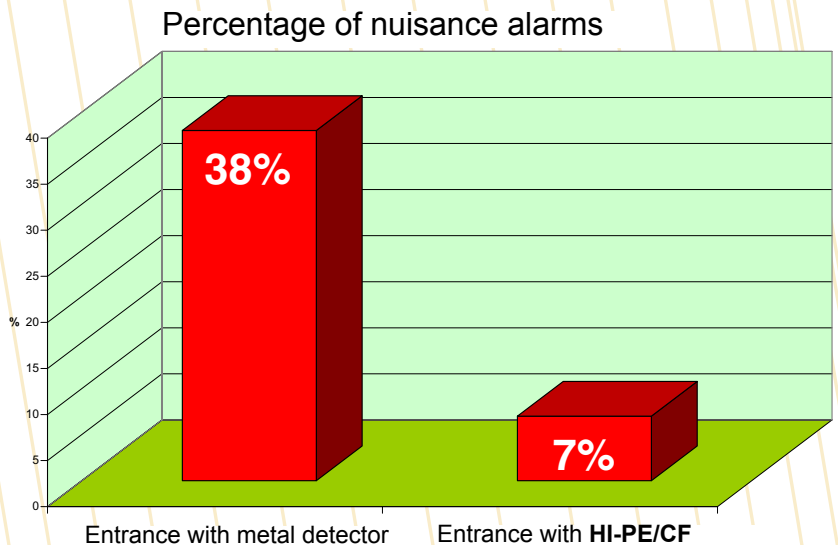

# HI-PE/CF

## Very High Discrimination Metal Detector



The transit of metal personal effects in common daily use through Metal Detector checkpoints generates signals which often exceed those of some types of fire-arm available on the market. Discrimination of these by the Metal Detector therefore becomes a necessary condition for establishing access systems with high flow rates.

As a solution to this problem, CEIA presents its new **HI-PE/CF** Metal Detector which, with its detection functions based on an innovative signal analysis system, raises the threshold of discrimination between medium-sized fire-arms and personal effects to a level up to 500% above that of the 02PN8 HI-PE model.

The advantages of using this new Metal Detector are the following: a notable reduction in the need for branch staff to act to check inward- and outward-bound traffic; increase in convenience of access to the bank for customers; and, not least, the opportunity to increase the level of security.

Statistical data obtained in real operating situations with the **HI-PE/CF** Metal Detector have demonstrated the almost total elimination of false alarms compared with earlier systems, at the same level of detection capability relating to fire-arms of conventional construction and in light metal, such as the Beretta 6.35mm.

The **HI-PE/CF** Metal Detector keeps the same dimensions and programming characteristics as the 02PN8 HI-PE Metal Detector, so that it can be fitted into systems which were designed for the earlier model. As far as its application is concerned, the parameters already in use for walk-through Metal Detectors remain valid, in particular the importance of the electromagnetic compatibility of the metal structure.

In order to guarantee the levels of performance described above, use of this new Metal Detector is restricted to cabins previously certified for electromagnetic compatibility with the **HI-PE/CF** Metal Detector.



## Technical Data

### Main Features

- Digitally adjustable sensitivity with a wide range of values.
- International Standards: Direct selection of the International Security Standards.
- Very high discrimination.
- Very high immunity to electromagnetic and mechanical interference.
- All functions programmable and controlled by a microprocessor.
- Programming: via built-in keypad and RDU or RS232/RS485 serial connection to PC or computer network.
- Programming access protected by both a mechanical lock and by two software level passwords.
- Automatic synchronization between two or more metal detectors, at a distance of up to 5 cm, from each other, without using cables.
- Professional high integration and high reliability electronics.
- Electronic control unit separated from the archway.
- No need for initial or periodic calibration.
- Easy maintenance. The electronic control unit can be replaced in less than one minute.
- Color: light gray RAL 7040

### Alarms

- Acoustic signal:
- Buzzer - 90 dBA (1 m)
- Relay outputs:
- NO, NC, C exchange contact - 1 A - 24 Vdc
- Reset:
- PP input, automatic or manual, N.C. contact
- Inhibition:
- INI input, N.O. contact
- Selfdiagnosis:
- Embedded, with intermittent acoustic signal

### Certifications and conformity

- Harmless to wearers of pacemakers or other vital support systems, pregnant women and magnetic storage media (floppy disks, audio cassettes, video cassettes and similar).
- Satisfies EC regulations and international standards relating to electrical safety and electromagnetic compatibility (EMC).

### Installation Data

- Power Supply:
- 20... 30 Vdc, 25W max
- Inputs:
- RS-232C interface for the connection with a terminal, a computer or an external modem
  - RS-232C interface for the network connection with other CEIA metal detectors
- Temperature and relative humidity:
- Working temperature: -10°C ... +65 °C (14...149°F);
  - Storage temperature: -35°C ... +70 °C (-31...158°F);
- Relative humidity: from 0 to 95% (without condensation)
- Dimensions and weight of the control unit:
- 380 x 157 x 82 mm (15"x6.2"x23.3") / 1.2kg (2.7lb)

### Accessories / Options

- Metallic test samples.

## 02PN8 HI-PE/CF-PN-AS-600

### Dimensions

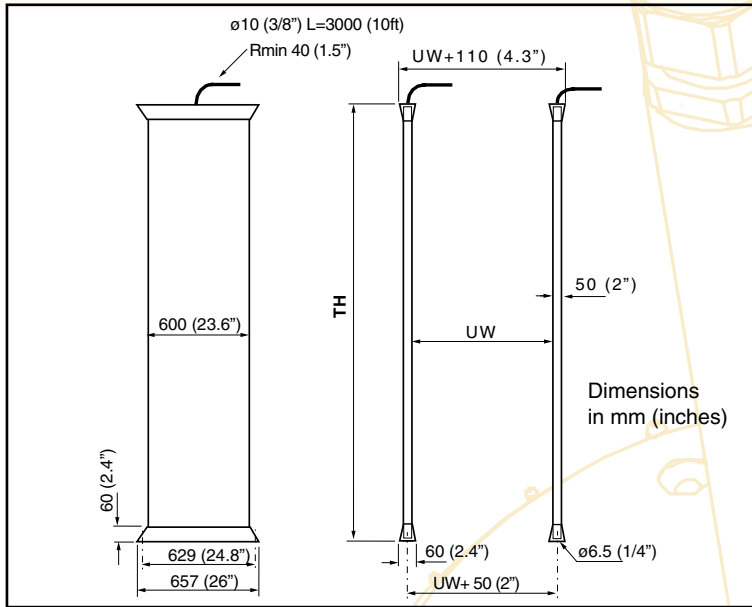

Model	HI-PE/CF-PN-AS-600
<b>UW</b>	680 ... 820 (26.8...32.3")
<b>TH</b>	2172 (85.5") 2220 (87.4")

## 02PN8 HI-PE/CF-PN-TR-600

### Dimensions

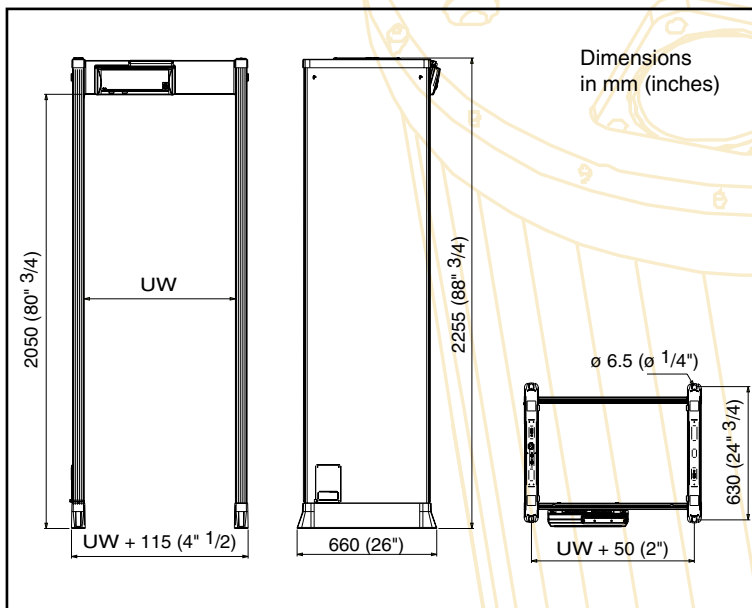

Model	HI-PE/CF-PN-TR-600
<b>UW</b>	720 / 820 (28.3"/32.3")

### Options

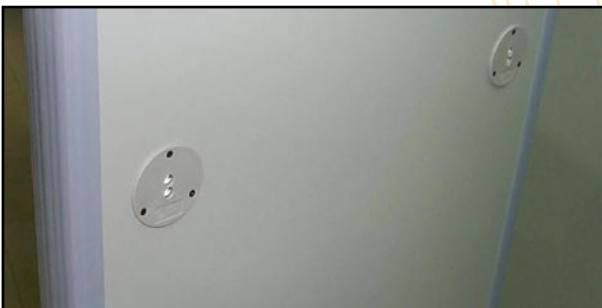

#### Transit Counter

Two photocells fitted into the antennae allow counting of transits, alarms and percentage of alarms.

# 02PN8 HI-PE/CF-AS-140

## Dimensions

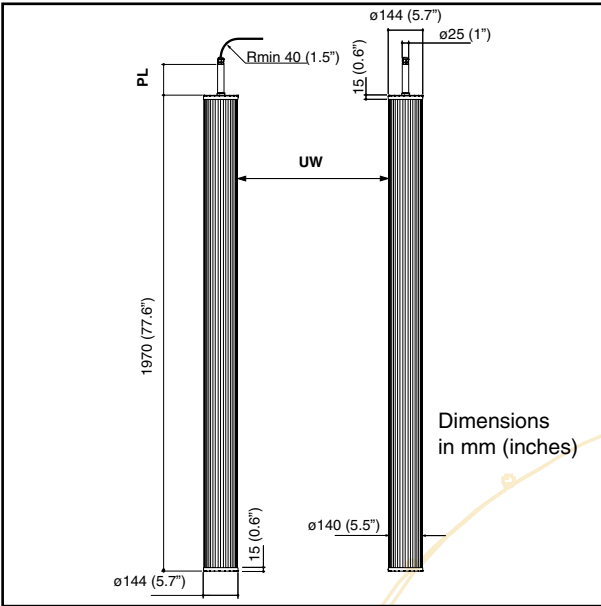

Model	HI-PE/CF-AS-140
<b>UW</b>	640 ... 740 (25...29'')
<b>PL</b>	40 (1.5'') 130 (5.1'') 250 (9.9'') 280 (11'')

Example of the model with options 2, 3 and 5 (see below)

## Options

Type of cable		Anchoring	
<p><b>1</b></p> <p>0,8m cable with connector, with 8m extension.</p>	<p><b>2</b></p> <p>Simple 3m cable.</p>	<p><b>3</b></p> <p><b>Anchoring without flange</b> Fixing via insertion of central conical support fixed to floor.</p>	<p><b>4</b></p> <p><b>Anchoring with flange</b> Fixing via a flange with holes as shown in the picture.</p>

Top fixing and cable exits		
<p><b>5</b></p> <p>Fixing via locking of the metal tube. The cable leads out of the middle of the tube.</p>	<p><b>6</b></p> <p>Fixing via direct locking of the column body. Axial cable exit.</p>	<p><b>7</b></p> <p>Fixing via central screw M10x12. Off-centre cable exit.</p>

## 02PN8 HI-PE/CF Elliptic

### Dimensions

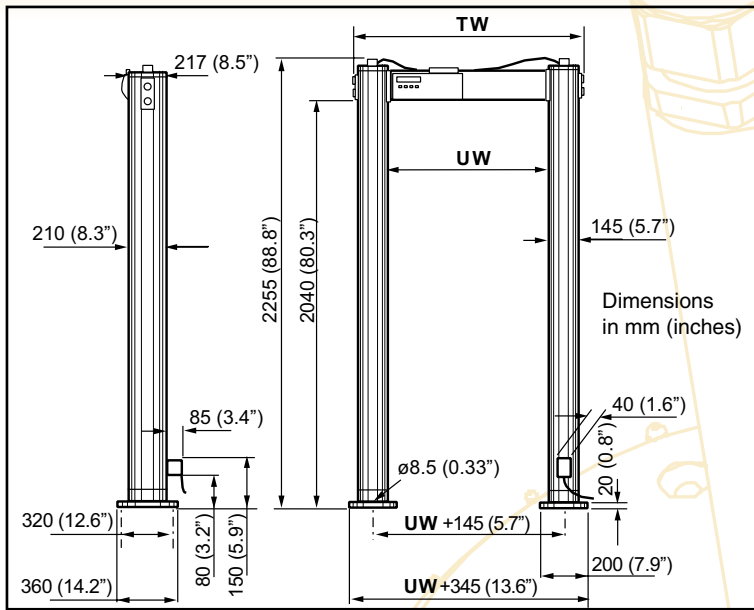

Model	HI-PE/CF-EN
<b>UW</b>	720 / 820 (28.3"/32.3")
<b>TW</b>	<b>UW + 320 (12.6")</b>

## 02PN8 HI-PE/CF Elliptic Waterproof

### Dimensions

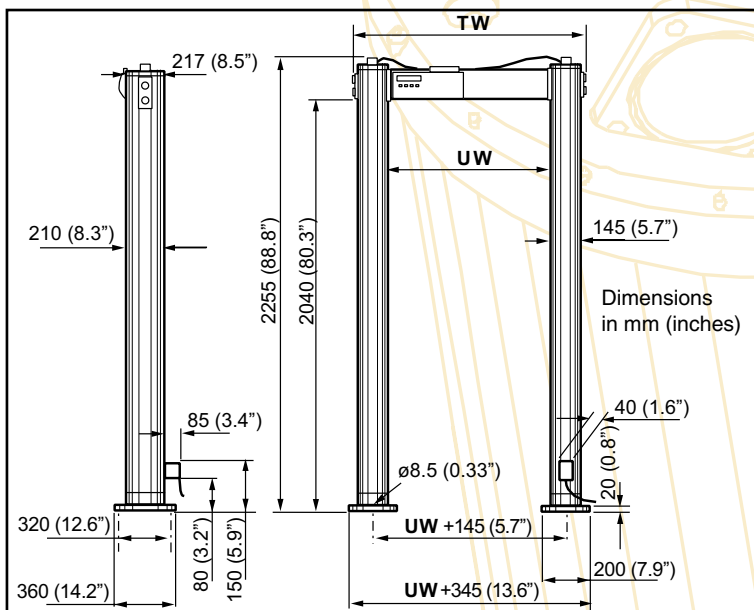

Model	HI-PE/CF-EW
<b>UW</b>	720 / 820 (28.3"/32.3")
<b>TW</b>	<b>UW + 360 (14.2")</b>